



BVMS Series (ANSI 150) – Submittal/Technical Data

Flanged Industrial Segmented Ball Valves 2-Way – 2" - 12"

Technical Specifications - BVMS Segmented Industrial Ball Valve Body		
Service	Chilled/Hot Water, 50/50 Glycol Solutions and Saturated Steam	
Size Range	2-Way	2" to 12" Flanged Segmented Valves
Maximum Fluid Temperature	Water	-20° to 380°F @ 200 PSI (-28° to 193°C @ 1378 kPa)
	Saturated Steam	100 psi (689 kPa) with upgraded AFLAS (FEPM) O-Ring
Valve Body Pressure Rating	ANSI Class 150	
Maximum Close-Off Pressure	Water	285 PSI (1965 kPa)
	Saturated Steam	100 PSI (689 kPa)
Maximum Recommended Operating Pressure Drop	1/3 of Inlet Pressure	
Flow Characteristic	Equal Percentage	
Rangeability	300:1	
Leakage	ANSI Class VI	
End Connections	ANSI Class 150	
Ambient Operating Temperature Range	See Actuator Rating (Optional high temperature mounting kit may be required)	
Materials	Body	ASTM A216 Gr WCB Carbon Steel
	Ball Segment	316 Stainless Steel
	Stem	ASTM A564 Type 630 Cond H1150D (17-4PH)
	Seat	Tek-Fil
	Stem Seal/Packing	PTFE + Graphite
	Gasket	PTFE
O-Ring	Viton (FKM) or Optional AFLAS (FEPM) for steam	
Warranty	3 Years limited from time of shipment.	

Disclaimer - The performance specifications are nominal and conform to acceptable industry standards. For application at conditions beyond these specifications consult the local Bray office. Bray, Inc. shall not be liable for damages resulting from misapplication or misuse of its products.

Application

The BVMS Series Industrial Ball valves are flanged segmented valves designed for control and On/Off applications where high temperature and high pressure water or steam are used. The valves feature a characterized ball segment for high rangeability with a splined stem connection for precise control, as well as a low friction shaft and thrust bearings for longer life and smaller actuators.

These valves provide ample flow capacity, equal percentage flow characteristics and Class VI leakage. Valve bodies are one-piece carbon steel with cast Stainless Steel balls and ANSI 150 flanges.

Features and Benefits

- **Characterized Ball Segment**

High Rangeability in excess of 300:1

- **ANSI Class VI Leakage Rating**

Suitable for HVAC applications

- **One Piece Phosphate Coated Carbon Steel Bodies**

For cost effective applications up to 380°F at 200 PSI

- **Available NEMA 4 Actuators**

Reliable, cost effective control

BVMS Series Ball Valves - Dimensions

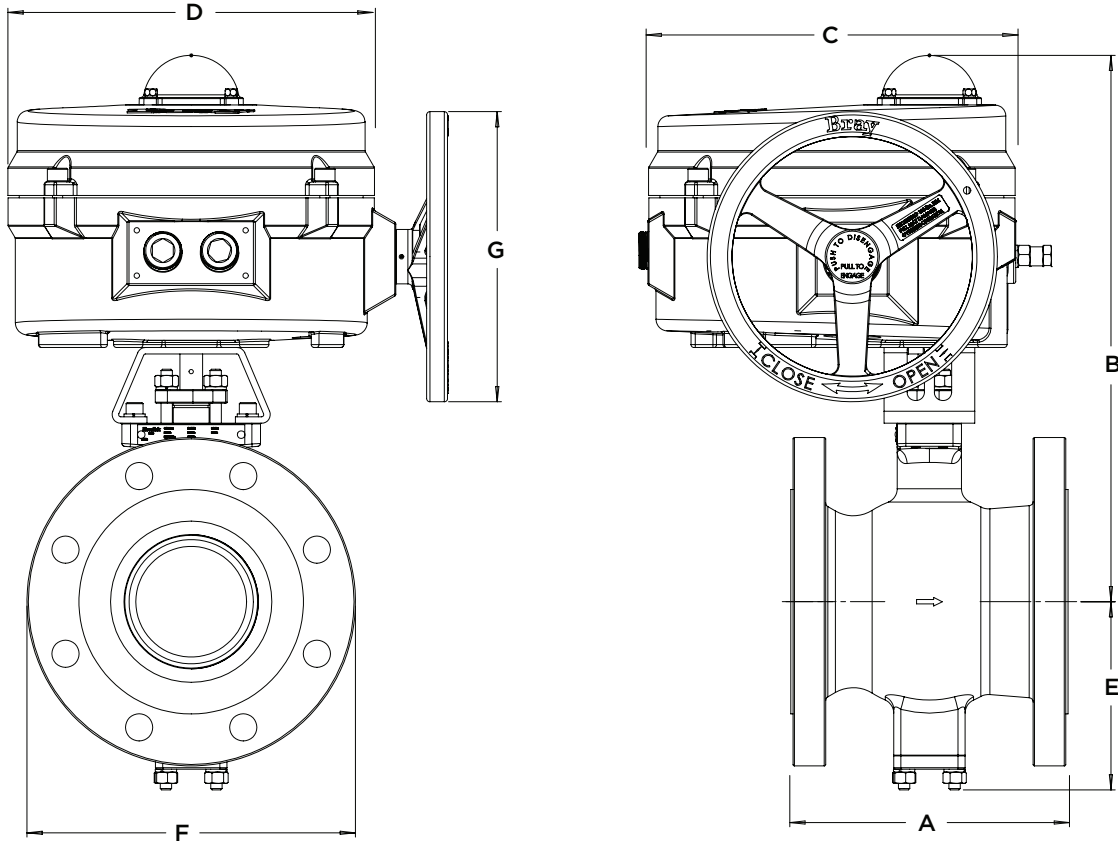

BVMS Dimensions - ANSI 150 - 2" - 12" - 2-Way, Segmented with Industrial Actuators - in. (mm)

Model Number	Valve Size		Flow Coefficient		A	B	C	D	E	F	G	Weight
	In.	mm	Cv	Kv								
BVMS2-C150-0095	2	50	95	82	4.9 (124)	12.9 (327)	9.3 (236)	7.5 (191)	3.9 (99)	6.0 (152)	3.5 (89)	17.9 [8.1]
BVMS3-C150-0287	3	80	287	247	6.5 (165)	12.9 (327)	9.3 (236)	7.5 (191)	4.8 (121)	7.5 (190)	3.5 (89)	32.0 [14.4]
BVMS4-C150-0436	4	100	436	375	7.6 (194)	15.0 (380)	12.1 (308)	10.1 (256)	5.2 (133)	9.1 (230)	8.0 (203)	45.2 [20.5]
BVMS6-C150-0760	6	150	760	654	9.0 (229)	19.0 (481)	12.1 (308)	10.1 (256)	7.6 (193)	11.0 (280)	8.0 (203)	86.0 [39.0]
BVMS8-C150-1350	8	200	1350	1161	9.6 (243)	20.1 (522)	13.1 (333)	12.1 (308)	8.4 (213)	13.6 (345)	12.0 (305)	131.0 [59.4]
BVMS10-C150-2380	10	250	2380	2047	11.7 (297)	20.1 (522)	13.1 (333)	12.1 (308)	10.1 (256)	16.0 (406)	12.0 (305)	191.0 [86.7]
BVMS12-C150-3410	12	300	3410	2933	13.3 (338)	25.8 (656)	14.8 (375)	12.1 (308)	11.5 (292)	19.0 (483)	12.0 (305)	302.0 [137.0]

Dimensions for largest Actuator shown
Weights (valve only) are in lbs. [kg in brackets]